

TECHNICAL MANUAL



PVL[®] Connecting Loop

Wall Connecting Loop Box with Single Wire

Version PEIKKO GROUP 02/2020



PVL® Connecting Loop

Single wire wall connecting loop

- Easy to install - individual boxes are installed to formwork.
- The flexible wire loop stays in opened position due to patented structure.
- Anchoring tail is easy to place into reinforcement.
- Step in the edges secures box into concrete.
- Three directional resistances calculated according to EN 1992-1-1.

PVL® Connecting Loops are single-wire loops for connecting precast wall panels to each other or to a column. PVL® Connecting Loops make wall installation easy: the protective tape can be easily removed and the loop can be then be bent to the operating position.

Wire loop boxes are installed to the formwork according to the spacing specified by the designer, before the panel is cast. After removing the formwork, the protective tape is removed, and the loop is bent out and straightened with a hammer claw or a pin. Wall panels are installed and supported according to plans. A vertical rebar is installed into a joint through the loops, and the horizontal position of the loops is checked. After completion of the formwork, the joint is finished by pouring or pumping the grout into the joint.

Standard wire lengths of 60 mm, 80 mm, 100 mm, 120 mm, and 140 mm are available for minimum wall thicknesses ranging from 80 mm to 150 mm.

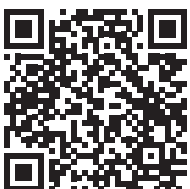

www.peikko.com

CONTENTS

About PVL® Connecting Loop	4
1. PRODUCT PROPERTIES	4
1.1 Structural behavior.....	5
1.1.1 Temporary conditions	5
1.1.2 Final conditions.....	5
1.2 Limitations for application.....	6
1.2.1 Loading and environmental conditions.....	6
1.2.2 Thickness of the concrete wall.....	6
1.2.3 Positioning of the PVL® Connecting Loop	7
1.3 Other properties.....	9
2. Resistances	10
2.1 Tensile resistance.....	10
2.2 Vertical shear resistance	11
2.3 Transverse shear resistance	11
2.3.1 Indented joint.....	11
2.3.2 Transverse shear resistance of smooth joint.....	13
2.4 Fire resistance.....	13
Selecting PVL® Connecting Loop	14
Annex A – Additional reinforcement	16
Annex B – Calculation of shear resistance with area of the joint	20
Installation of PVL® Connecting Loop.....	22
INSTALL THE PRODUCT – PRECAST FACTORY	22
INSTALL THE PRODUCT – CONSTRUCTION SITE.....	25

About PVL® Connecting Loop

1. PRODUCT PROPERTIES

PVL® Connecting Loops are used for connecting structural or non-structural precast concrete wall elements to create wall-to-wall or wall-to-column connections. PVL® Connecting Loops consist of a recess box, a wire loop, and a protective tape.

Wire Loop boxes are installed to the formwork according to spacing specified by designer, before the panel is cast. A pair of boxes and the vertical rebar installed into loops form together with the concrete grout a joint which resists shear forces and tensile forces.

PVL® Connecting Loops are available in various models that are suitable for different applications.

Figure 1. PVL® Connecting Loops in the joint of wall panels.

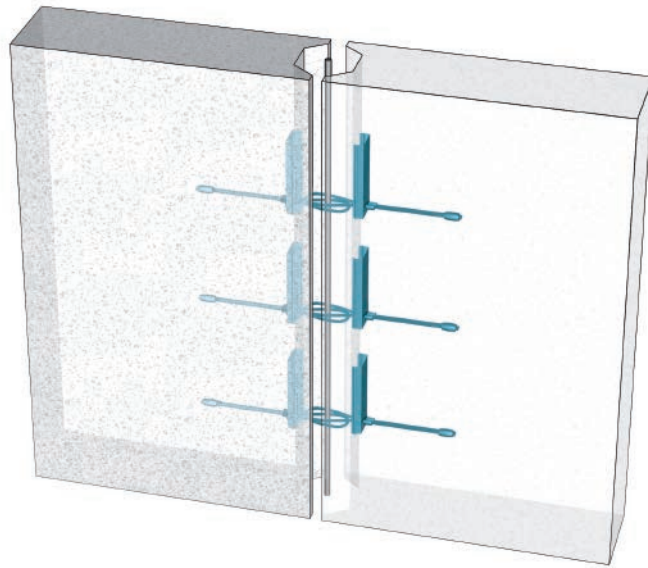

PVL® SOLO is available for situations where higher vertical shear resistance is required than achievable with standard PVL® Connecting Loop models.

1.1 Structural behavior

PVL® Connecting Loop is designed to transfer vertical shear forces, transverse shear forces, tensile forces, and their combinations in wall-to-wall or wall-to-column connections. They are designed to use the indented surface of the wall joint for transferring shear forces (either vertical or transverse). The indented arrangement of the joint (see *Figure 2* and *Figure 3*) develops a strut-and-tie model in the connection, where compression is transferred by “concrete strut” and tension is transferred by “wire loop tie”.

Figure 2. Strut-and-tie model for vertical shear load transfer.

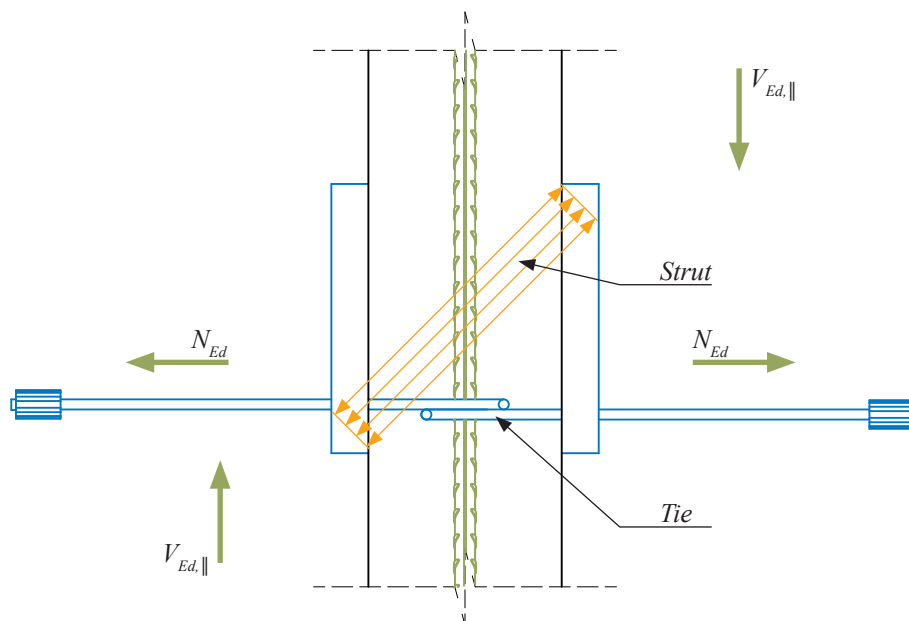
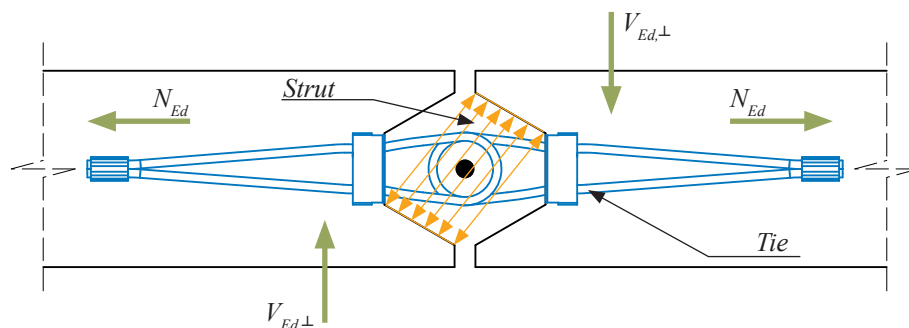

Figure 3. Strut-and-tie model for transverse shear load transfer.



Note: The joint connected by PVL® Connecting Loops works as a hinged joint in case of transverse loads. It is not possible to transfer any bending moments with the connection.

1.1.1 Temporary conditions

PVL® Connecting Loops are not designed to transfer any loads during erection stage as the joint is not yet filled with grout. Stability of the concrete precast element during erection stage must be secured by other measures, like a temporary bracing system. The open joint must be grouted with non-shrink grout, and grout must reach the required design strength before the wall is loaded by another structure.

1.1.2 Final conditions

In the final stage, after grouting has reached the required strength, the connection can be assumed as load-bearing. The connection can now be loaded by other structures and it transfers loads by a strut-and-tie model explained in Section 1.1.

1.2 Limitations for application

Standard models of PVL® Connecting Loops are pre-designed for use under conditions mentioned in Section 1.1. If these conditions are not met, please contact Peikko Technical Support.

1.2.1 Loading and environmental conditions

PVL® Connecting Loops are designed to transfer static loads. Resistances of connecting loops are determined in accordance with EN 1992-1-1:2004 and EN 1992-1-2:2004. In the case of dynamic or seismic loads please contact Peikko Technical Support.

The connecting loop is designed for use in either indoor or outdoor conditions. The recess box together with the wire loop are manufactured with a galvanized surface treatment. The concrete cover of the PVL® Connecting Loop, including wire loop and recess box, must fulfill minimum requirements determined by EN 1992-1-1: section 4.4.1 to ensure resistance against corrosion.



PVL® Connecting Loops shall not be used for lifting a wall element. JENKA Lifting System from the Peikko product portfolio can be used for such purposes.

1.2.2 Thickness of the concrete wall

Minimum thickness values of the wall panels and the joint width are given in Table 1.

Table 1. Minimum wall thickness values and joint width.

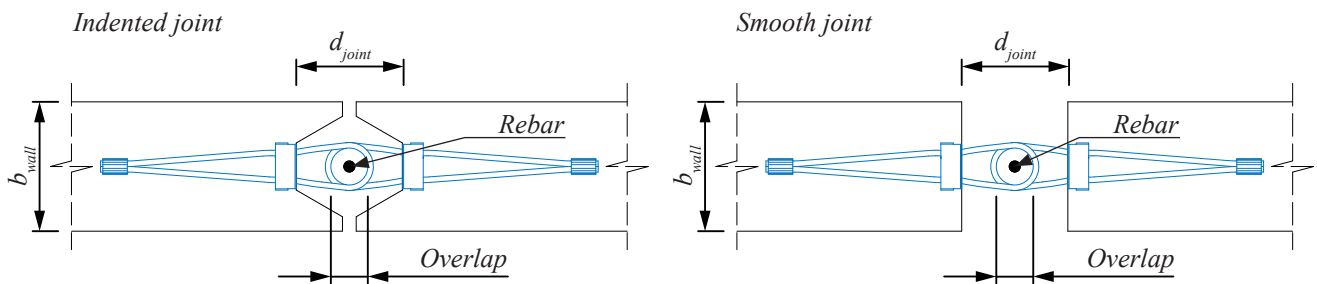

PVL® Connecting Loop	b_{wall} [mm]	d_{joint} [mm]	Overlap [mm]
PVL® 140	150	160	120
PVL® SOLO	150	100	60
PVL® 120	120	140	100
PVL® 100	120	120	80
PVL® 80	80	100	60
PVL® 60	80	80	40

Note: Walls with thickness smaller or equal than 80 mm are considered as non-load-bearing walls.

1.2.3 Positioning of the PVL® Connecting Loop

PVL® Connecting Loops are designed to be used in reinforced concrete walls or columns with minimum concrete grade of C25/30 or higher. The structural properties of the PVL® Connecting Loops are guaranteed only if the grouting material has at least the same compressive strength as the precast wall.

The resistances of PVL® Connecting Loop presented in this manual are determined for minimum geometry of the indented joint as follows.

Figure 4. Minimum dimensions of the joint for PVL®60-120.

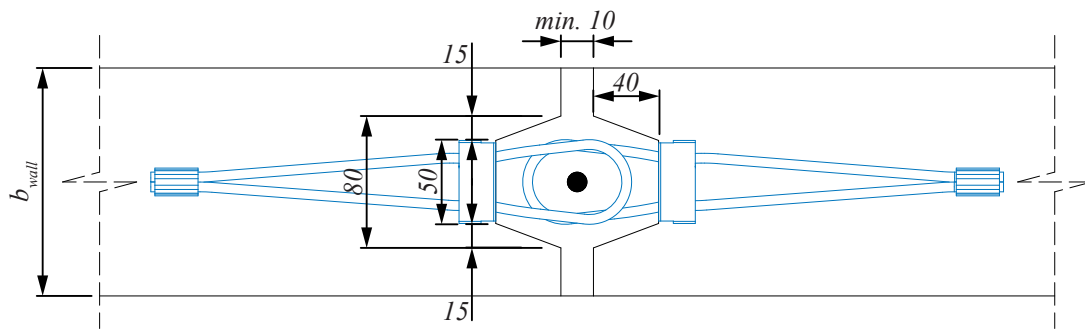

Figure 5. Minimum dimensions of the joint for PVL®140.

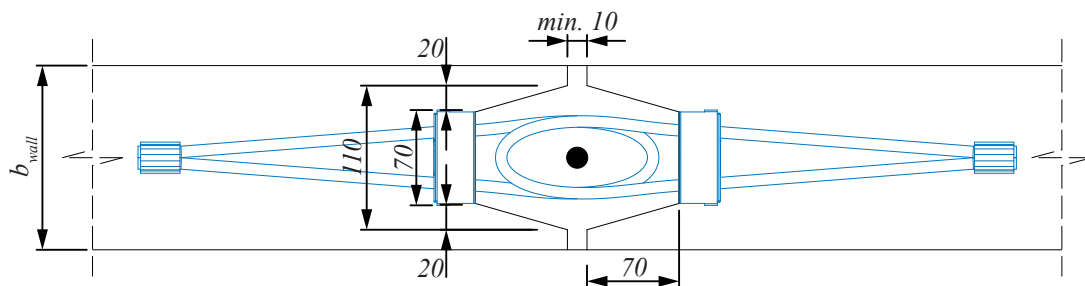
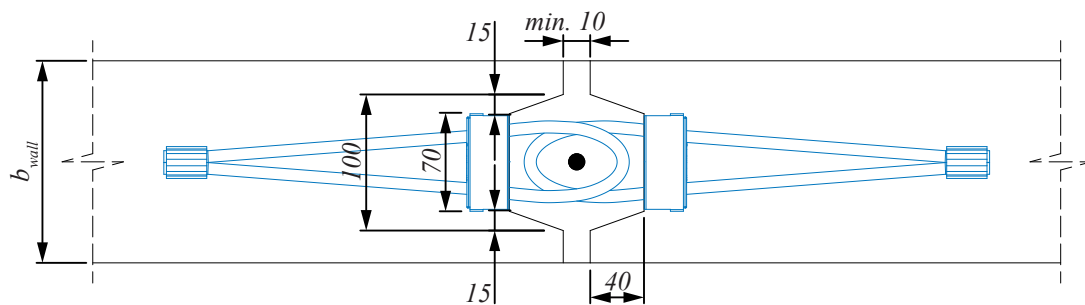

Figure 6. Minimum dimensions of the joint for PVL®SOLO.



INFORMATION

The resistance of the precast wall joint depends on spacing of the PVL® Connecting Loops in the wall.

Figure 7. Minimum spacing requirements for PVL® Connecting Loop.

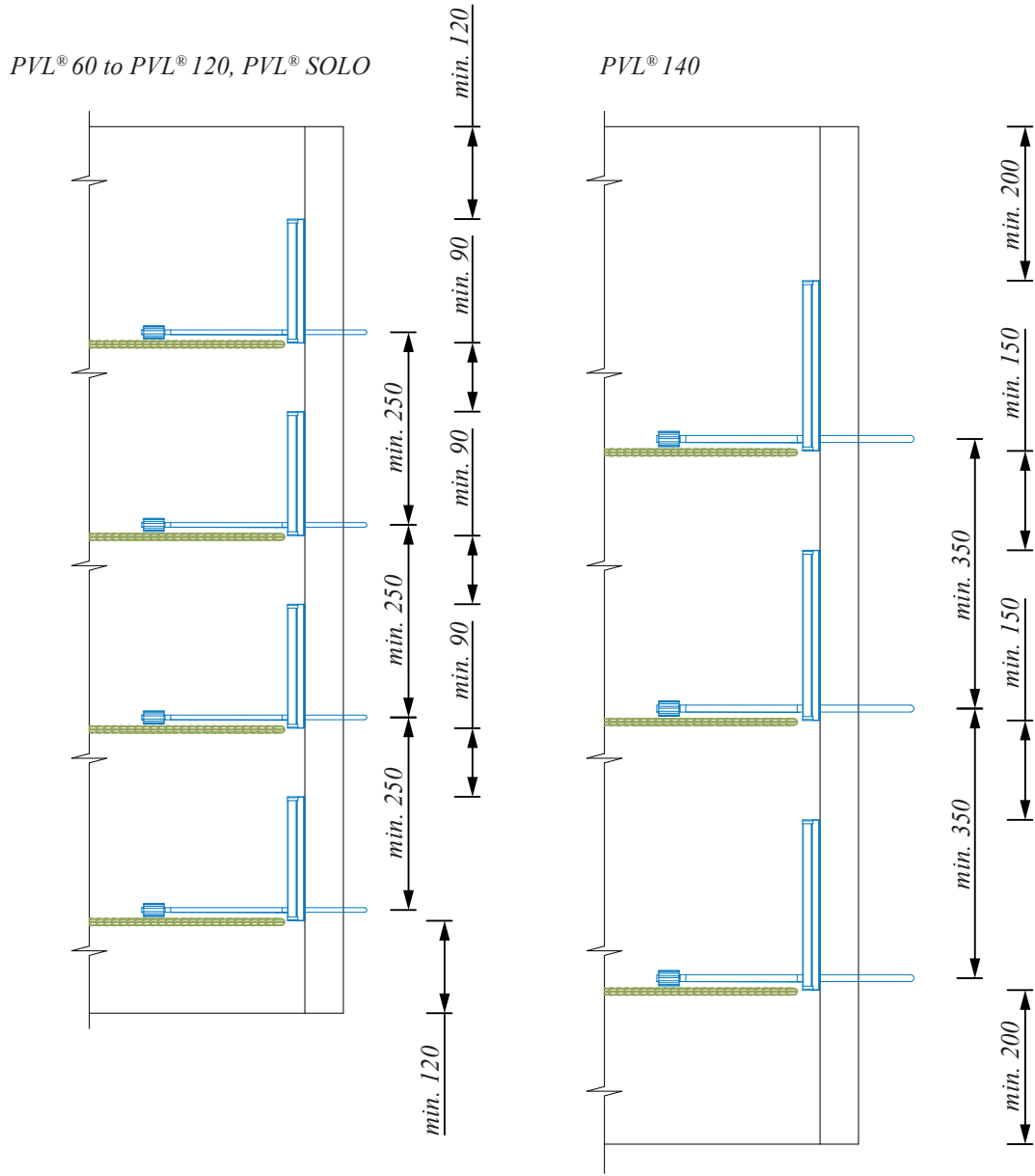

1.3 Other properties

PVL® Connecting Loops are fabricated from components with the following material properties:

Box	Galvanized metal sheet	JIS G3302
Ferrule	Alloyed steel	EN 13411-3 GB/T 8162-2018
Protective tape	Duct tape	
Wire loop	$R_r = 1770$ MPa	EN 12385-2 GB/T 20118-2006

Peikko Group’s production units are externally controlled and periodically audited on the basis of production certifications and product approvals by various independent organizations.

Table 2. Manufacturing tolerances.

Wire loop length	± 2.0 mm
Box length	± 2.0 mm

Dimensions of standard PVL® Connecting Loops are summarized in Table 3.

Table 3. Dimensions of PVL® Connecting Loops.

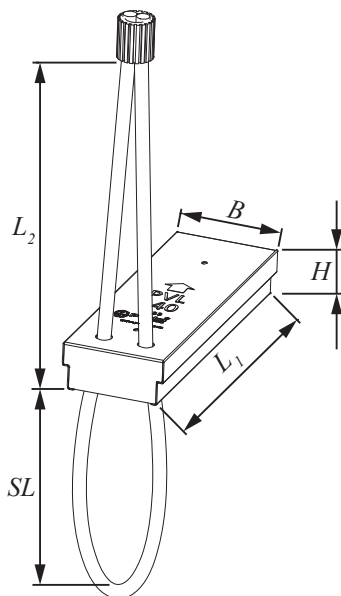

PVL®	L_1 [mm]	L_2 [mm]	B [mm]	H [mm]	SL [mm]	Wire \varnothing [mm]
PVL® 140	200	232	70	32	140	9
PVL® 120	160	182	50	22	120	6
PVL® 100					100	
PVL® 80					80	
PVL® 60					60	
PVL® SOLO	120	232	70	32	80	9

2. Resistances

Resistances of joint with PVL® Connecting Loops are defined according to loop spacing and compressive strength of the concrete grout in the joint. Resistances are determined by a design concept that refers to the following standards:

- EN 1990-1
- EN 1992-1-1:2004
- EN 1992-1-2: 2004



Please note that wall element must have sufficient resistance to transfer all loads from the wire loop joint. Proper design of the wall element must be handled during structural design of the whole building.

2.1 Tensile resistance

Table 4. Tensile resistance of PVL® Connecting Loop.

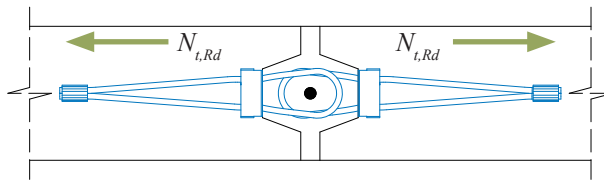

Grouting/wall	Tensile resistance $N_{t,Rd}$ [kN/pair of boxes]					
	C25/30	C30/37	C35/45	C40/50	C45/55	C50/60
PVL® 60-120	10.7	12.8	15.0	17.1	19.3	21.4
PVL® 140	25.6	30.7	35.8	36.1	36.1	36.1
PVL® SOLO	25.6	30.7	35.8	36.1	36.1	36.1



Please note that tensile resistances of PVL® Connecting Loop presented in Table 4 are per one pair of boxes.

$$\Sigma N_{t,Rd} = \eta_{PVL} \cdot N_{t,Rd} \text{ [kN/m]} \tag{1}$$

Where:

η_{PVL} = Number of PVL® Connecting Loop pairs per 1 m length of joint [pcs]

2.2 Vertical shear resistance

Table 5. Vertical shear resistance of PVL® Connecting Loop.

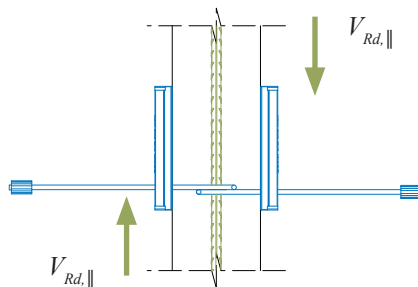

Grouting/wall	Vertical shear resistance $V_{Rd, }$ [kN/pair of boxes]					
	C25/30	C30/37	C35/45	C40/50	C45/55	C50/60
PVL® 60-120	14.5	16.9	19.4	22.1	24.6	27.1
PVL® 140	31.5	37.0	42.5	44.2	45.1	46.0
PVL® SOLO	28.1	33.3	38.4	39.5	40.1	40.6



Please note that vertical shear resistances of PVL® Connecting Loop presented in Table 5 are per one pair of boxes.

$$\Sigma V_{Rd,||} = \eta_{PVL} \cdot V_{Rd,||} \text{ [kN/m]} \quad (2)$$

Where:

η_{PVL} = Number of PVL® Connecting Loop pairs per 1 m length of joint [pcs]

2.3 Transverse shear resistance

2.3.1 Indented joint

Table 6. Transverse shear resistance $V_{Rd,\perp,l}$ for PVL® 60-120

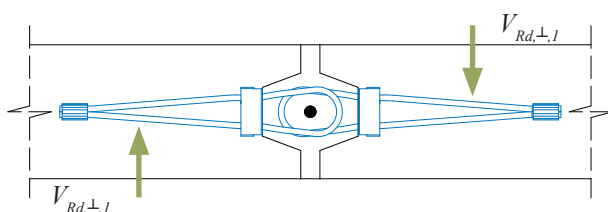

Wall thickness [mm]	Transverse shear resistance $V_{Rd,\perp,l}$ [kN/m]					
	C25/30	C30/37	C35/45	C40/50	C45/55	C50/60
120	-	-	-	-	-	-
140	17.2	19.1	21.0	23.9	25.8	27.7
150						
160						
170						
180						
190						
≥200						

INFORMATION

Table 7. Transverse shear resistance $V_{Rd,\perp,1}$ for PVL® 140.

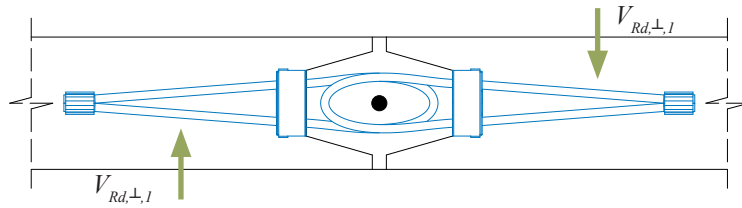

Wall thickness [mm]	Transverse shear resistance $V_{Rd,\perp,1}$ [kN/m]					
	C25/30	C30/37	C35/45	C40/50	C45/55	C50/60
120	-	-	-	-	-	-
140	-	-	-	-	-	-
150	7.7	8.6	9.5	10.7	11.6	12.5
160	9.8	10.9	12.0	13.6	14.7	15.8
170	12.1	13.4	14.8	16.8	18.2	19.5
180	14.6	16.3	17.9	20.4	22.0	23.6
190	17.4	19.4	21.3	24.2	26.2	28.1
200						
210						
220						
230						
240						
250						
260						
270						
280						
290						
300						

Table 8. Transverse shear resistance $V_{Rd,\perp,1}$ for PVL® SOLO.

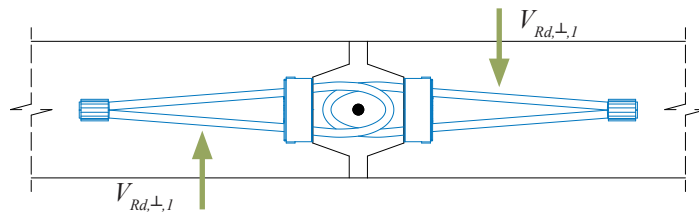

Wall thickness [mm]	Transverse shear resistance $V_{Rd,\perp,1}$ [kN/m]					
	C25/30	C30/37	C35/45	C40/50	C45/55	C50/60
120	-	-	-	-	-	-
140	-	-	-	-	-	-
150	13.6	15.1	16.6	18.8	20.4	21.9
160						
170						
180						
190						
200						
210						
≥220						

Note: Resistance values presented in *Table 6*, *Table 7*, and *Table 8* are precalculated assuming that the geometry of the joint is in accordance with *Figure 4*, *Figure 5*, and *Figure 6*. If different geometry is used, resistances for transverse shear must be calculated separately.

2.3.2 Transverse shear resistance of smooth joint

Table 9. Transverse shear resistance $V_{Rd,\perp,2}$ for plain PVL® Connecting Loop.

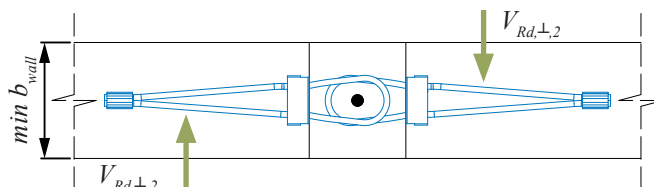

Wall thickness [mm]	Min. b_{wall} [mm]	Transverse shear resistance $V_{Rd,\perp,1}$ [kN/pair of boxes]					
		C25/30	C30/37	C35/45	C40/50	C45/55	C50/60
PVL® 60-120	120	3.0	3.3	3.7	4.2	4.5	4.8
PVL® 140	150	3.4	3.7	4.1	4.7	5.1	5.4
PVL® SOLO	150	2.0	2.2	2.4	2.8	3.0	3.2



Please note that transverse shear resistances of PVL® Connecting Loop presented in *Table 9* are per one pair of boxes.

$$\Sigma V_{Rd,\perp,2} = \eta_{PVL} \cdot V_{Rd,\perp,2} \text{ [kN/m]} \tag{3}$$

Where:

η_{PVL} = Number of PVL® Connecting Loop pairs per 1 m length of joint [pcs]

2.4 Fire resistance

If PVL® Connecting Loops are used in load-bearing walls, the concrete cover thickness must be effective enough so that the wire loop will not reach its critical temperature $T_{crit} = 350^\circ\text{C}$. Minimum thickness of the wall must fulfil requirements according to EN 1992-1-2: 2004; section 5.4.

Note: It is not allowed to use PVL® Connecting Loops for fire walls which are required to resist impact loading (criterion M according to EN 1992-1-2 section 2.1.2 (6)).

Selecting PVL® Connecting Loop

The following aspects must be considered when selecting the appropriate type of PVL® Connecting Loop to be used in a wall connection:

- Wall thickness
- Geometry of the joint
- Load-bearing capacity

Verification

If no tensile forces are acting in the joint, the connection can be verified according to equation (4).

$$\frac{V_{Ed,\parallel}}{V_{Rd,\parallel}} + \frac{V_{Ed,\perp}}{V_{Rd,\perp}} \leq 1.0 \tag{4}$$

Cases where tensile load is acting in the connection together with shear loads must be verified according to the following equation.

$$\frac{N_{Ed}}{\sum N_{t,Rd}} + \frac{V_{Ed,\parallel}}{0.67 \cdot \sum V_{Rd,\parallel}} + \frac{V_{Ed,\perp}}{\sum V_{Rd,\perp,2}} \leq 1.0 \tag{5}$$

Where:

- N_{Ed} = Tensile load in joint [kN/m]
- $V_{Ed,\parallel}$ = Vertical shear load in joint [kN/m]
- $V_{Ed,\perp}$ = Transverse shear load in joint [kN/m]
- $N_{t,Rd}$ = Tensile resistance of joint [kN/m]
- $V_{Rd,\parallel}$ = Vertical shear resistance of joint [kN/m]
- $V_{Rd,\perp,2}$ = Transverse shear resistance of smooth joint [kN/m]



Note: At least 2 pairs of PVL® Connecting Loops shall be placed in each joint.

Design example 1:

Concrete grade of the wall: **C30/37**
 Grouting: **C30/37**
 Wall thickness: **120 mm**
 Vertical shear load per height of wall: $V_{Ed,\parallel} = 62.7 \text{ kN}$

Design:

PVL®100
 Spacing 400 mm

Number of PVL® pairs per length of joint:

$$\eta_{PVL} = 3,000 / 400 = 7.5 \text{ pcs} \Rightarrow \text{Selected 7 pcs/height of wall}$$

Vertical shear resistance of PVL® Connecting Loops:

$$V_{RD,\parallel} = \eta_{PVL} \times V_{Rd,\parallel} = 7 \times 16.9 = 118.3 \text{ kN}$$

Verification:

$$\frac{V_{Ed,\parallel}}{\sum V_{Rd}} = \frac{62.7}{118.3} = 0.53 < 1.0$$

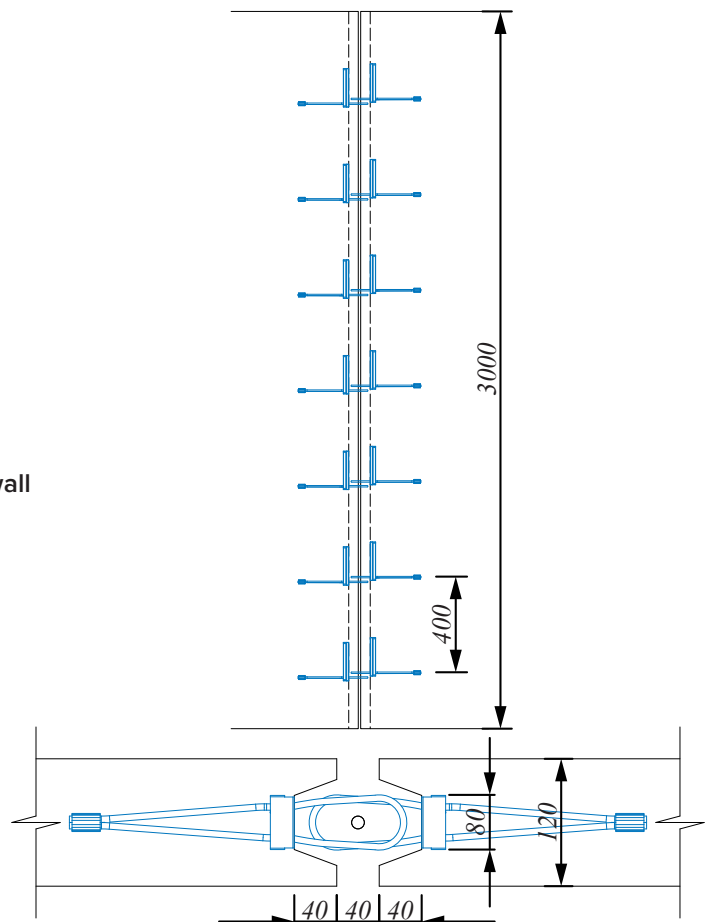

Design example 2:

Concrete grade of the wall: C30/37
 Grouting: C30/37
 Wall thickness: 120 mm
 Vertical shear load per height of wall: $V_{Ed,\parallel} = 62.7 \text{ kN}$
 Transverse shear load per height of wall: $V_{Ed,\perp} = 22.15 \text{ kN}$

Design:
 PVL[®]100
 Spacing 250 mm

Number of PVL[®] pairs per length of joint:
 $\eta_{PVL} = 3,000 / 250 - 1 = 11 \text{ pcs}$

Vertical shear resistance of PVL[®] Connecting Loops:

$$V_{RD,\parallel} = \eta_{PVL} \times V_{Rd,\parallel} = 11 \times 16.9 = 185.9 \text{ kN}$$

Transverse shear resistance of PVL[®] Connecting Loops:

$$V_{RD,\perp} = \eta_{PVL} \times V_{Rd,\perp} = 11 \times 3.37 = 37.07 \text{ kN}$$

Verification:

$$\frac{V_{Ed,\parallel}}{\sum V_{Rd,\parallel}} + \frac{V_{Ed,\perp}}{\sum V_{Rd,\perp}} = \frac{62.7}{185.9} + \frac{22.15}{37.07} = 0.94 < 1.0$$

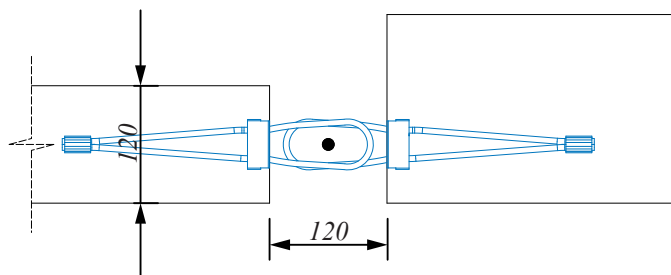
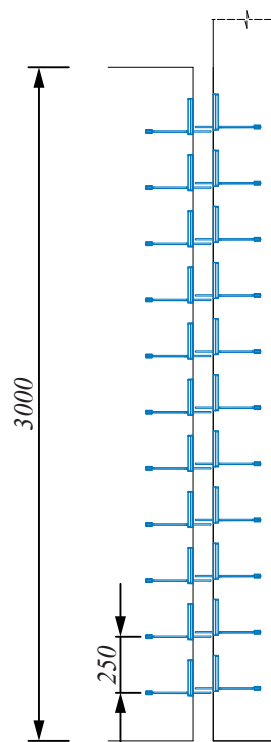

Annex A – Additional reinforcement

Additional reinforcement in form of U-stirrups should be used if tensile load is applied to connection or if spacing of wire loop boxes is smaller than 600 mm. U-stirrups should be used also if wire loop boxes are closer than 450 mm to edge of wall. Already existing reinforcement in wall element can be assumed as additional reinforcement if fulfills minimum requirements according to this section. U-stirrups are placed as close as possible to wire loop tail and anchored properly to concrete element.

The additional reinforcement in form of U-stirrups should be always used in PVL® 140 or PVL® SOLO are used for joint connection.

Figure 8. Reinforcement at wall end with PVL® Connecting Loops.

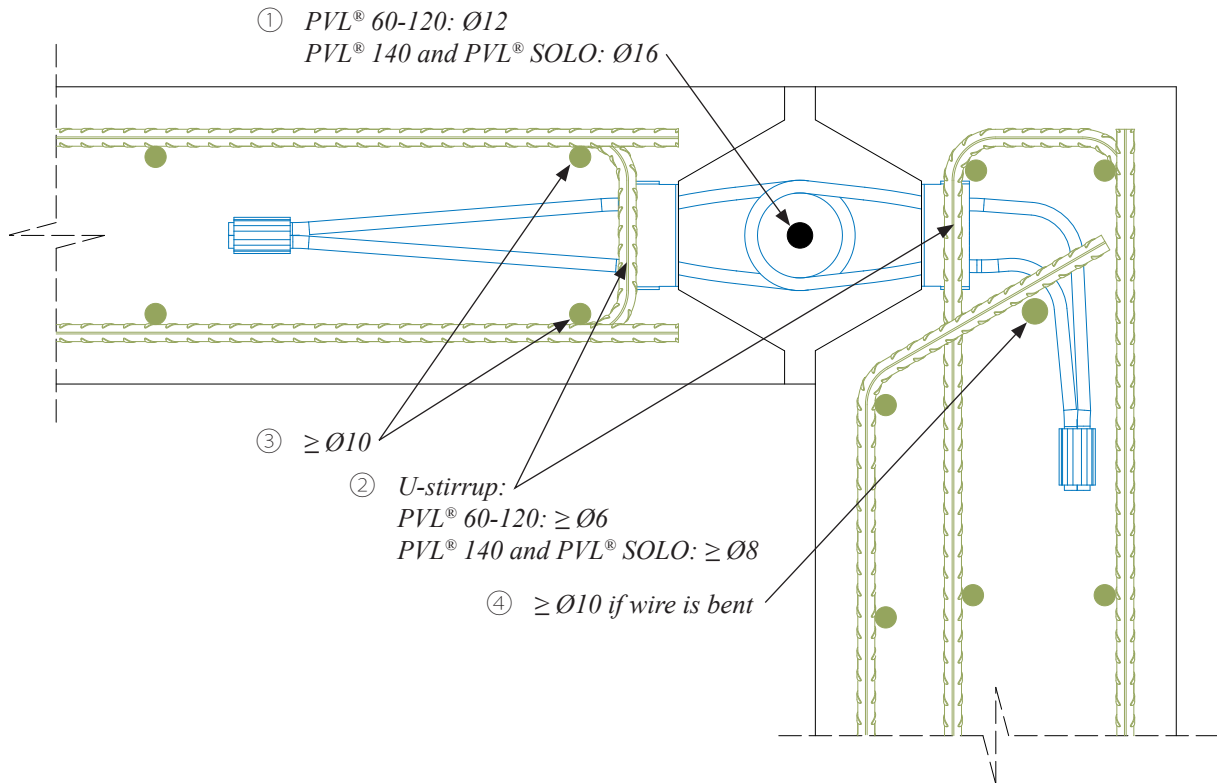
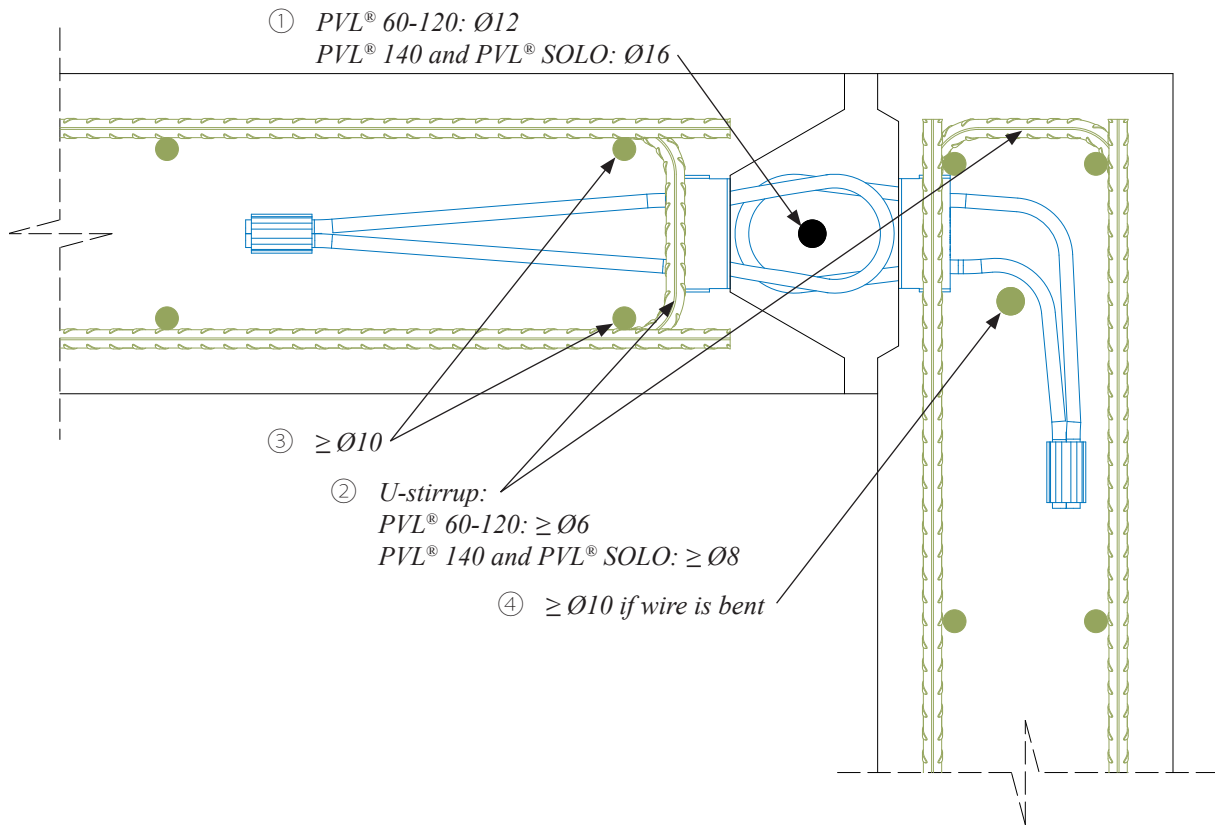

Figure 9. Reinforcement at wall end with PVL® Connecting Loops.



Optional arrangement PVL® Connecting Loops and additional reinforcement.

Figure 10. Options for additional reinforcement for PVL®60 – PVL®120.

Mesh on both surfaces

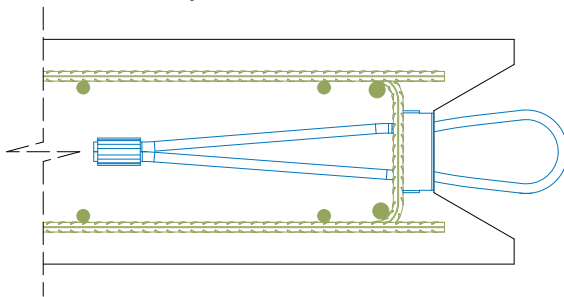

In case of load-bearing walls loaded by shear and tensile loads:

- Mesh on both surfaces min. Ø6 k150
- U-stirrups:
PVL® 60-120: Ø8 or 2×Ø6
PVL® 140 and PVL® SOLO: Ø10 or 2×Ø8
- Edge reinforcement min. 2Ø10

Central mesh

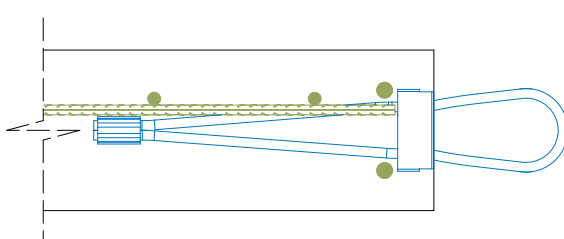

Narrow wall elements only with middle reinforcement mesh.

- Mesh min. Ø6 k150
- No tensile load
- Spacing of loops is bigger than 600 mm
- Edge reinforcement min. 2×Ø10
- Note: If tensile load is applied or spacing is smaller than 600 mm then U-stirrups should be used.

Figure 11. Additional reinforcement for PVL®60 – PVL®120 and PVL® SOLO.

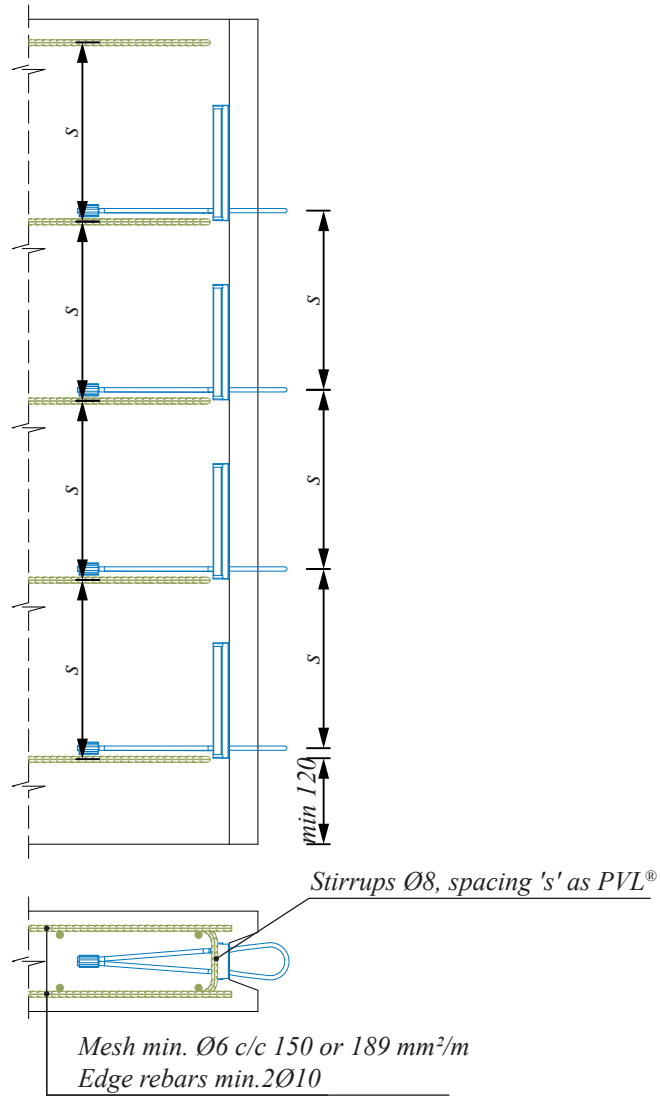
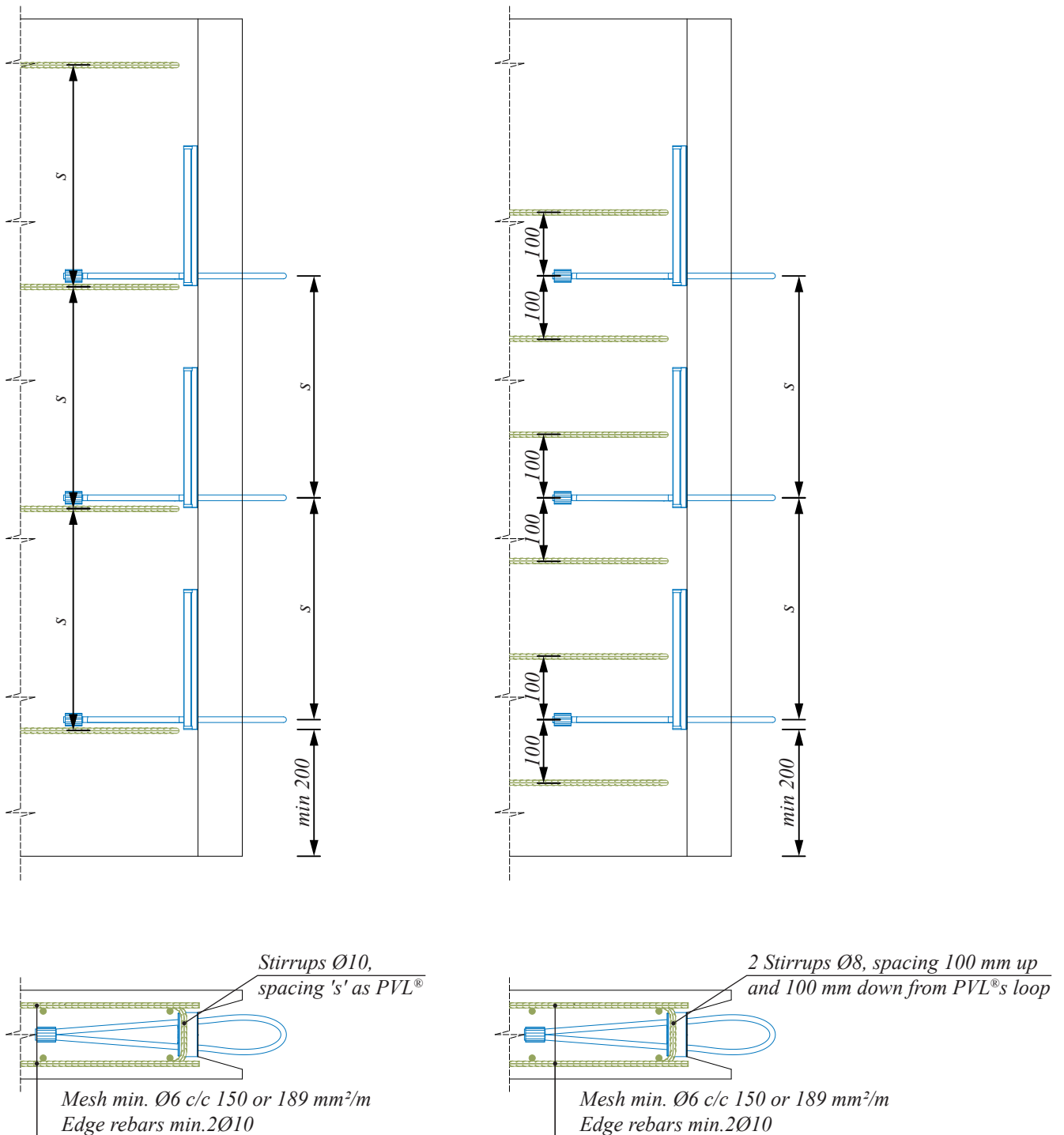

Figure 12. Options for additional reinforcement for PVL®140.



Annex B – Calculation of shear resistance with area of the joint

Annex B determines the calculation procedure for joints, which are not covered by standard resistances presented in this technical manual or for the situation where also surface of the joint is included to resistance. Calculation procedure is available for vertical shear resistance and transverse shear resistance.

Figure 13. Arrangement of the semi-smooth joint/general joint.

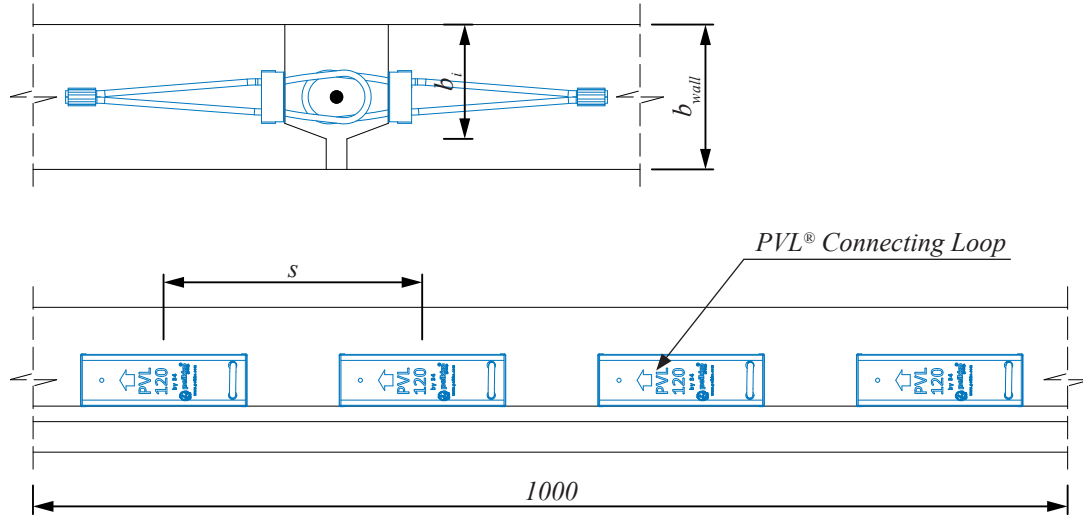
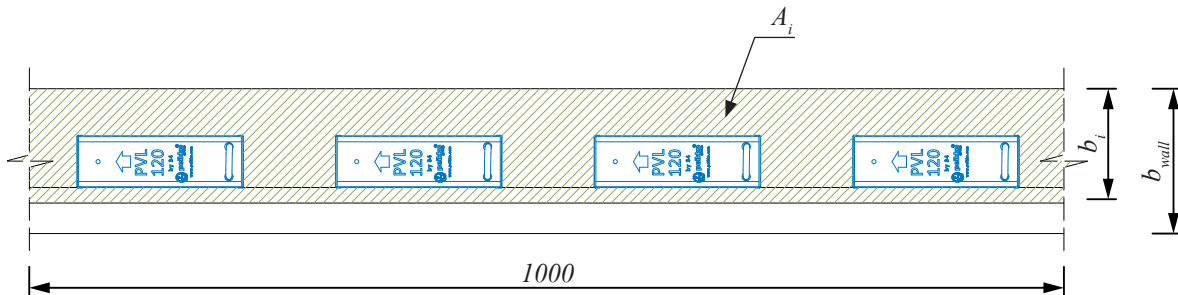

Figure 14. Concrete surface used to transfer shear loads by friction.



Vertical shear resistance

Vertical shear resistance of general joint depends on the number of PVL® Connecting Loop pairs per one-meter length of the joint and on the surface area of the joint (reduced by area of PVL® Connecting Loops), which transfers load by friction. Vertical shear resistance per 1 m length of joint is determined by the following equation:

$$V_{Rd,||,2} = \eta_{PVL} \cdot V_{Rd,||} + c \cdot f_{ctd} \cdot A_i / 1000 \text{ [kN/m]} \tag{6}$$

$$A_i = b_i \cdot 1000 \text{ mm} - \eta_{PVL} \cdot B \cdot L_l \tag{7}$$

Where:

- η_{PVL} = Number of PVL® Connecting Loop pairs per 1 m length of joint [pcs]
- $V_{Rd,||}$ = Vertical shear resistance of a pair of PVL® boxes, section 2.2 [kN/pair of boxes]
- c = Friction coefficient for very smooth surface, 0.025 [-] EN 1992-1-1; section 6.2.5
- f_{ctd} = Design value of tensile resistance of concrete [MPa] EN 1992-1-1; section 6.2.5
- b_i = Effective width of the joint [mm]
- B = Width of PVL® Connecting Loop, Table 5 [mm]
- L_l = Length of PVL® Connecting Loop, Table 5 [mm]

Transverse shear resistance

Transverse shear resistance of general joint is calculated in the same way as vertical shear resistance. Transverse shear resistance depends on the number of PVL® Connecting Loop pairs per one-meter length of the joint and on the surface area of the joint (reduced by area of PVL® Connecting Loops), which transfers load by friction. Transverse shear resistance per 1 m length of joint is determined by the following equation:

$$V_{Rd,\perp,3} = \eta_{PVL} \cdot V_{Rd,\perp,2} + c \cdot f_{ctd} \cdot A_i / 1000 \leq V_{Rd,\perp,1} \quad [kN/m] \quad (8)$$

Where:

- η_{PVL} = Number of PVL® Connecting Loop pairs per 1 m length of joint [pcs]
- $V_{Rd,\perp,2}$ = Transverse shear resistance of a pair of PVL® boxes, *Table 9* [kN/pair of boxes]
- $V_{Rd,\perp,1}$ = Transverse shear resistance of indented joint, *Table 6*, *Table 7* or *Table 8* [kN/m]
- A_i = Reduced area of the joint by area of PVL® Connecting Loops; equation (7)
- c = Friction coefficient for very smooth surface; 0.025 [-] EN 1992-1-1; section 6.2.5
- f_{ctd} = Design value of tensile resistance of concrete [MPa] EN 1992-1-1; section 6.2.5

Note: Please note that if the connection is loaded also by tensile forces, the Vertical shear resistance and Transverse shear resistance determined by friction $c \times f_{ctd}$ is equal to 0 and only resistance developed by PVL® connecting box shall be used.

Installation of PVL® Connecting Loop

INSTALL THE PRODUCT – PRECAST FACTORY

The PVL® Connecting Loops are placed into the reinforcement of the wall and fixed through recess boxes to formwork according to the installation drawing. The wall edge is reinforced by additional reinforcement according to Annex A. Installation tolerances of PVL® Connecting Loops must fulfil requirements according to *Table 10*.

Profiled shape of the formwork can be created either by plywood channel or steel channel. The connection of the recess boxes to the formwork channel depends on the used material. In the case of wood or plywood use, the PVL® Connecting Loops can be attached by nails through holes in recess boxes. In the case of steel formwork use, PVL® Installation magnets can be used to attach the PVL® Connecting Loops to the surface.

After casting the wall and loops, and when the concrete has achieved the required strength, the formwork and protective tapes can be removed. Loops can then be bent out and straightened by using a hammer claw. Due to the structure of the wire, loops will remain in the opened horizontal position.

Table 10. Installation tolerances for PVL® Connecting Loop.

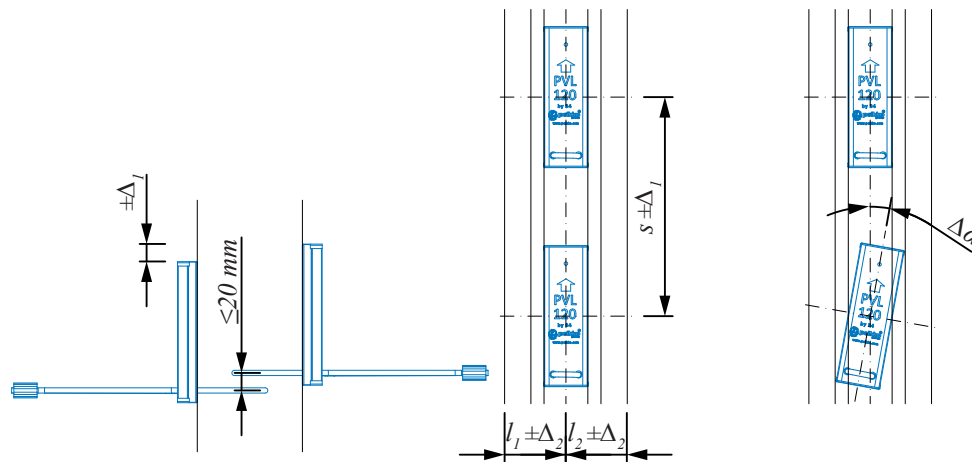

Δ_1	Δ_2	$\Delta\alpha$
$\pm 10 \text{ mm}$	$\pm 3 \text{ mm}$	$\pm 0 \text{ deg}$

Figure 15. Installation of the PVL® Connecting Loop to wooden formwork: a) directly to side of formwork; b) to the wooden recess channel.

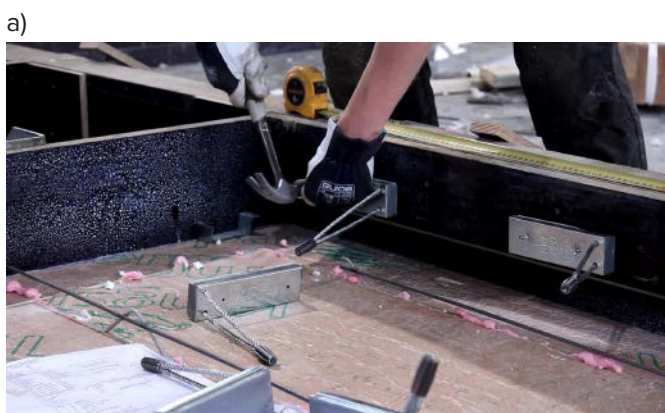

Accessories

PVL® Magnetic plate

If a steel formwork is used, PVL®'s recess box can be attached by a magnetic plate. Magnetic plates are available in two models:

- **PVL® Installation magnet** – available for PVL®60 – PVL®120
- **PVL® Installation magnet 140-SOLO** – available for PVL®140

Table 11. Dimensions of PVL® Installation Magnets.

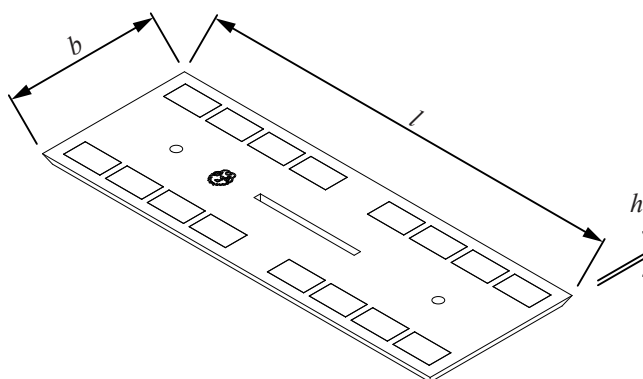

	Length l [mm]	Width b [mm]	Thickness h [mm]	Weight [kg]	Magnetic force [kN]
PVL® Installation magnet	178	67.5	5	0.41	1.0
PVL® Installation magnet 140-SOLO	213	73	5	0.54	1.3



Due to strong magnetic forces, it is highly possible that sudden attachment of metal objects or two magnetic plates could occur, which can lead to severe injury.



The strong magnetic field can lead to damage of electronic devices, like cell phones, computers, credit cards, or data storage devices. Also, hearing aids and pacemakers may be interfered when they are in close proximity to a magnetic plate.

Operating instructions

Metal and other covers should be removed before the introduction of the magnet. The slot in the installation magnet for the removal tool should be covered with tape from both sides to ensure no concrete gets in the joint during casting. The alignment of the magnets should be as accurate as possible from the very start (*Figure 16*). Moving the magnet to correct position by hitting or impact of hammer can cause damage to the formwork or welded joints of steel formwork. Fixing of the PVL® Installation magnet should follow installation tolerances according to *Table 10*.



Weakening of magnets may occur when they are in direct contact with a foreign magnetic field, such as electric welding, electric cables, or other strong magnetic fields, and in temperature of over 80°C.

INSTALLING

Figure 16. Attaching PVL® Installation magnets to steel formwork.

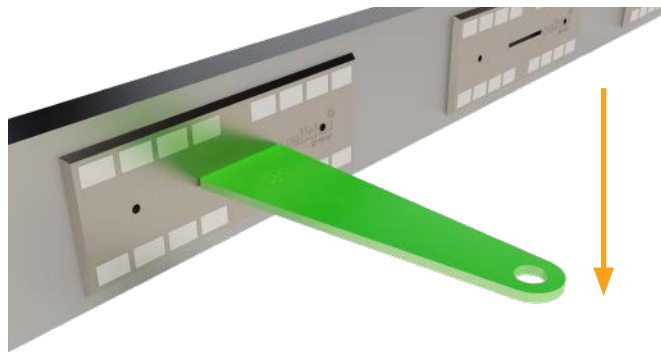

Figure 17. Connecting PVL® recess box to installation magnet.



The magnets can be removed from the steel surface by using a removal tool (Figure 18). The tool should be placed in the PVL® installation magnet slot, and the magnet is removed by levering. Debris should be removed, and the surface of the magnets should be cleaned from all concrete particles. Magnets should be stored clean and dry but also away from each other, min. 15 mm distance.

Figure 18. Removing installation magnet from formwork.



Magnet maintenance

Magnets are more sensitive to corrosion than plain steel parts. Especially moisture (including road salt) accelerates corrosion. Steel and rubber magnet moldings must be removed, cleaned and oiled at regular intervals to prevent corrosion.

INSTALL THE PRODUCT – CONSTRUCTION SITE

Wall panels are installed according to plan drawings and erection sequence, always with the existence of a temporary bracing system which provides stability (*Figure 19*). The wire loops in the joint are adjusted to be perpendicular to the surface of the joint (*Figure 20*) and to fulfill the installation tolerances according to *Table 9*. Vertical reinforcement (*Table 10*) is placed through all wire loops (see *Figure 21* and *Figure 22*). The length of the reinforcement must be equal to the height of the joint.

Figure 19. Precast wall installed at final position and secured by temporary bracing.



Figure 20. Wire loop with correct installation angle to wall joint.

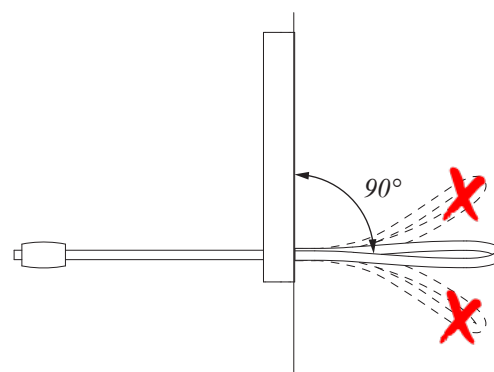

NOTE: The wire maintains its full strength in normal use, where a maximum of 3 open-close bindings take place.

INSTALLING

Table 12. Diameter of the transverse reinforcement for PVL® Connecting Loops.

	PVL®60 – PVL®120	PVL®140; PVL® SOLO
Min. diameter of transverse reinforcement B500B	Ø 12	Ø 16

Figure 21. Incorrect installation of wire loops.
Spacing between loops is bigger than 20 mm



Wrong position of the loop, outside of rebar, short transverse bar



Figure 22. Correct installation of wire loops.



Position of wire loops before placement of the longitudinal rebar

Based on the dimensions of the joint, formwork can be created, and concrete grout is poured or pumped in to joint (Figure 23). Concrete grout shall have at least the same compression strength as the concrete of the wall panels, minimum C25/30. Non-shrinking grouting material must be used with maximum aggregate size according to dimensions of the joint. The environmental conditions like temperature and humidity must be considered in accordance with EN 13670-1 during casting of the grouting material to the joints.

Figure 23. Casting of the joint.

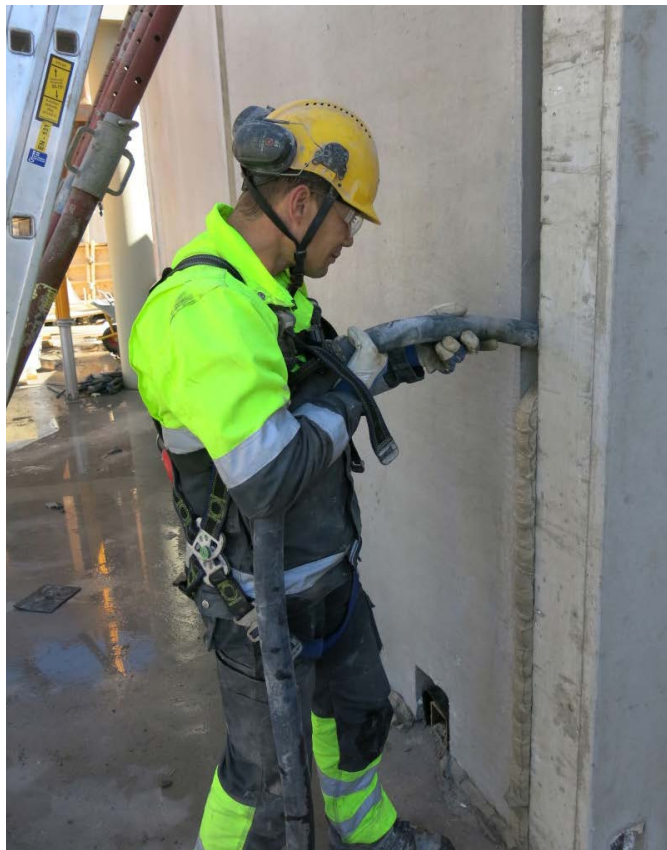

Figure 24. Finished wall joint.



Revisions

Version: PEIKKO GROUP 02/2020. Revision: 003

- Correction in Section 1.2.1.
- Correction in Section 2.4.
- Removed Wall Type from Table 1.

Version: PEIKKO GROUP 05/2019. Revision: 002

- Revisions to resistances and content
- Branding brought up to 2018 styles.

Version: PEIKKO GROUP 04/2018. Revision: 001*

- New cover design for 2018 added.

Resources

DESIGN TOOLS

Use our powerful software every day to make your work faster, easier, and more reliable. Peikko design tools include design software, 3D components for modeling programs, installation instructions, technical manuals, and product approvals of Peikko's products.

peikko.com/design-tools

TECHNICAL SUPPORT

Our technical support teams around the world are available to assist you with all of your questions regarding design, installation etc.

peikko.com/technical-support

APPROVALS

Approvals, certificates, and documents related to CE-marking (DoP, DoC) can be found on our websites under each products' product page.

peikko.com/products

EPDS AND MANAGEMENT SYSTEM CERTIFICATES

Environmental Product Declarations and management system certificates can be found at the quality section of our websites.

peikko.com/qehs

COMPANY WITH
MANAGEMENT SYSTEM
CERTIFIED BY DNV
ISO 9001 • ISO 14001
ISO 45001