

Wind turbine foundation optimizer



**CHOOSE
LOWEST CO₂ EMISSION**
onshore wind turbine foundations

Peikko's Gravity
Foundation

-25%



Peikko's Screw Pile
Foundation

-30%

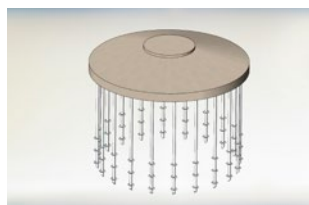

Peikko's Cage Rock
Foundation

-50%



Peikko's Rock
Foundation

-70%

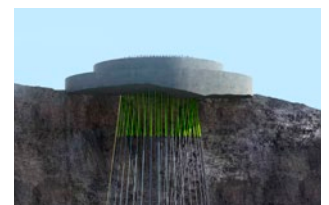

GRAVITY FOUNDATIONS

GRAVITY FOUNDATIONS FOR MEDIUM-SIZED TURBINES

Peikko's Gravity Foundation design is constantly fine-tuned. With every iteration, we have been able to cut the costs and time needed for installation.

The latest design uses **60 to 80 m³ less concrete** compared to the previous design generation. On top of that, the traditional Gravity Foundation needs **six tons less reinforcement**, making for lower CO₂ emissions.



LOWEST CO₂ EMISSION ONSHORE WIND TURBINE FOUNDATIONS

OPTIMIZE THE CARBON FOOTPRINT OF YOUR WIND FARM

Wind energy has a low carbon footprint by default. With clever foundation choices, you can achieve even lower life cycle emissions.

The demand for low carbon footprint energy solutions is on the rise. Consequently, total life cycle emissions are starting to matter in the wind business as well.

Peikko is the first player in the market to have carried out a life cycle assessment for its wind turbine foundations.

The cost-efficiency and low CO₂ footprint of Peikko's gravity foundations result from effective use of components, reinforcement, and concrete. This reduces site assembly and construction time. In addition to being good for the planet, lower CO₂ emissions mean better profitability.



SCREW PILE FOUNDATION

Advanced screw piles are designed for the needs of wind turbine foundations. They provide fast, and easy assembly with a conventional excavator screwing adaptor. This increases pile contractor options for foundation executions. Peikko offers design, instructions, and procedures for controlling the whole process.

Manufacturing on Peikko premises ensures fast delivery time. In addition, savings of foundation concrete volumes benefit on-site concrete management.



GRAVITY FOUNDATIONS FOR ALL SOIL AND TURBINE TYPES

Conventional gravity foundations need a lot of concrete. This is not only problematic from a CO₂ perspective; the availability of concrete can also be an issue. Peikko always aims to lower the amount of concrete and steel used.

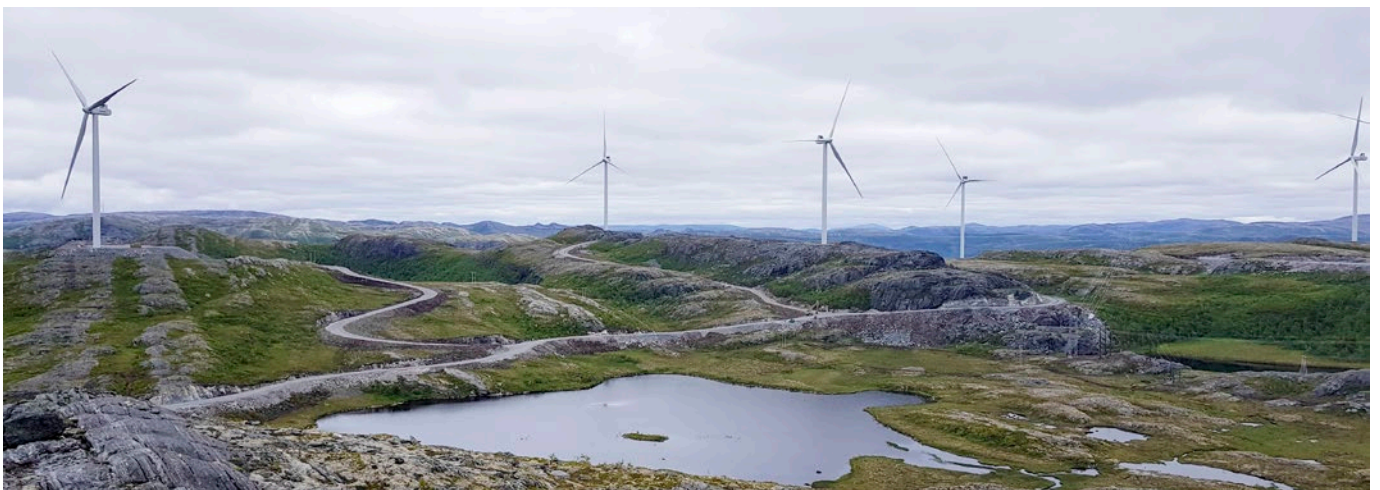

ROCK FOUNDATIONS

ROCK FOUNDATIONS FOR THE LOWEST CO₂ EMISSIONS

Peikko's Rock Foundation integrates design, production and planning of assembly with all key components manufactured in-house. The result is a safe, reliable, cost-efficient and easy-to-build foundation that uses a minimum amount of concrete.



AIMING FOR EFFICIENCY AND LOW CARBON FOOTPRINT

Optimizing the carbon footprint of a foundation starts in the design phase. The optimal technical solution is a combination of steel and concrete that is as efficient as possible.

Research conducted by Bionova shows that our solutions offer a remarkably reduced carbon footprint. The study was done by comparing a traditional gravity foundation with Peikko's Gravity Foundation system, new Rib Gravity Foundation, and Rock Foundation.

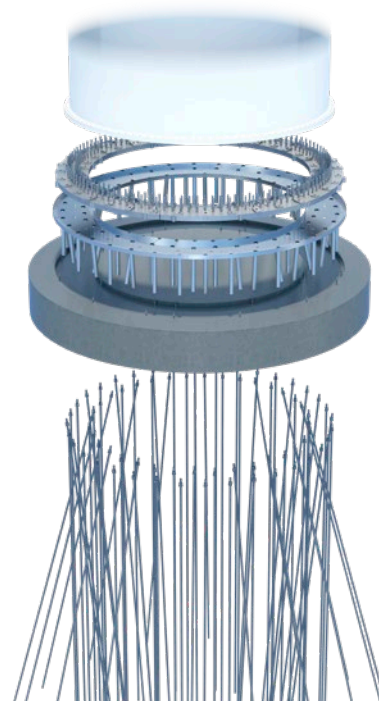
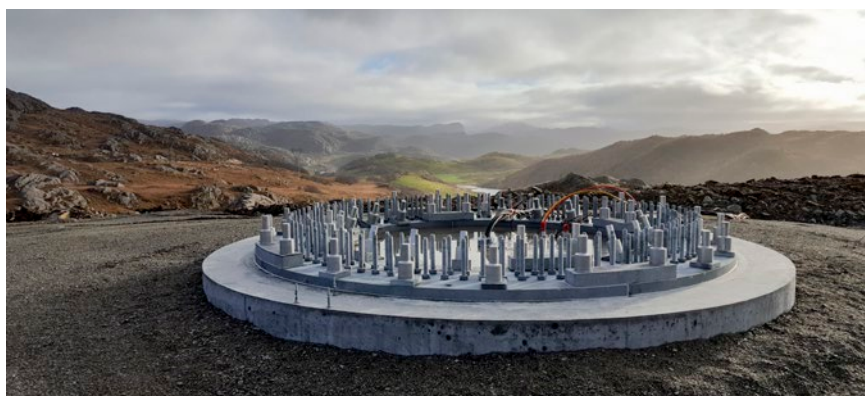

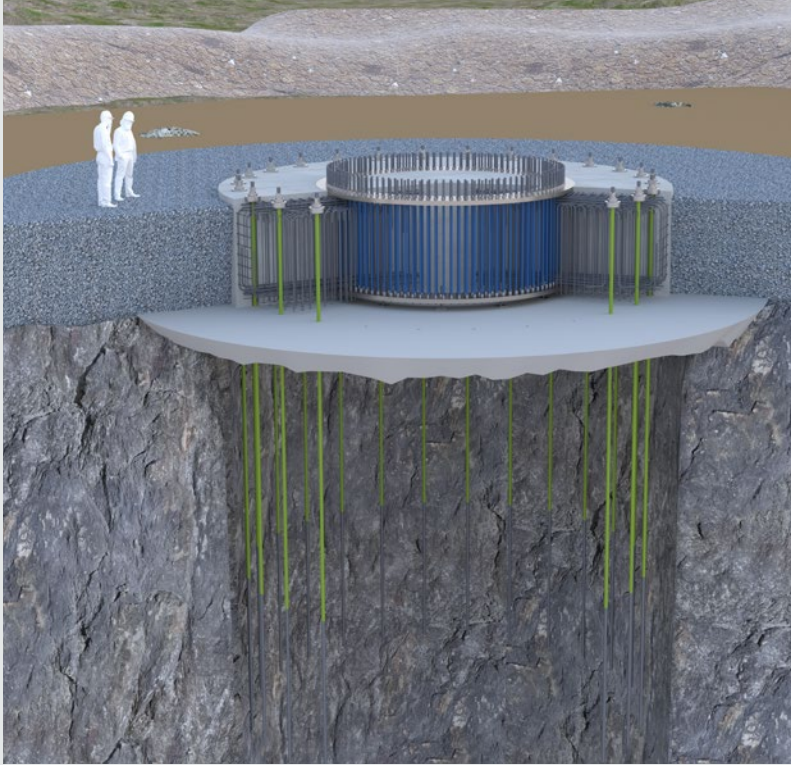

CAGE ROCK FOUNDATION

With introduction of Cage Rock Foundation, Peikko offers a complete range of foundation solutions for rocky sites. Depending on the site conditions and cost drivers, customers can choose between range of solutions gaining highest construction speed, lowest costs and CO₂ emission.

Compared to Gravity Foundation, Cage Rock solution provides about 70% concrete and reinforcement saving.

ANCHOR CAGE MADE TO MEASURE

With application in Cage Rock and Gravity Foundations, custom height anchor cages are enabling even better foundation design, and concrete and reinforcement savings.

Peikko's streamlined design and manufacturing process ensure delivery time starting from two weeks. The delivery contains anchor bolts or complete anchor cage sets.

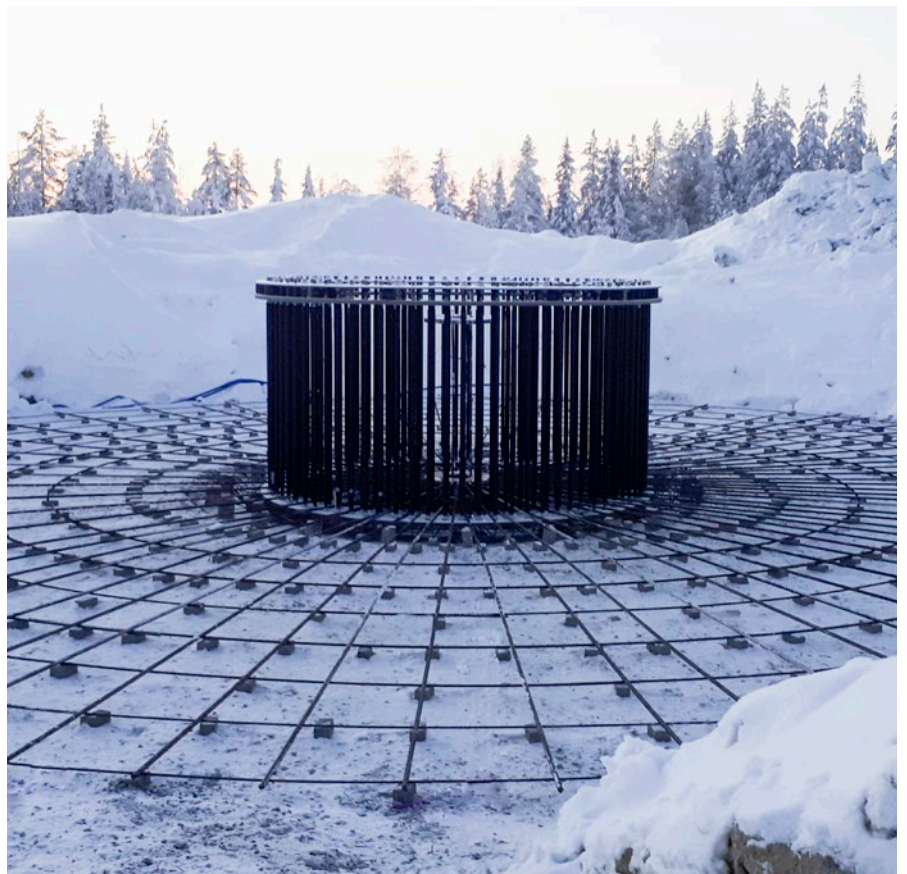

EFFICIENCY BY DESIGN



Normally it takes four to eight weeks to get a full foundation design from an engineering company or a structural designer. If there are different soil types in the area chosen for your wind park, even more weeks are lost doing additional designs.

Done in the traditional way, your designer comes up with a general gravity foundation design for the dominant soil type within the park. As the conventional design work is costly and takes a lot of time, you need to make sure that the soil on every turbine site fits the foundation design. In practice, this means changing soil at those sites where it differs from the dominant soil type.

Peikko has changed the game. We can create a preliminary design in just one day. This is the fastest way to assess the cost of a foundation. You can have a dedicated design for each soil type, and avoid costly and time-consuming soil changes.

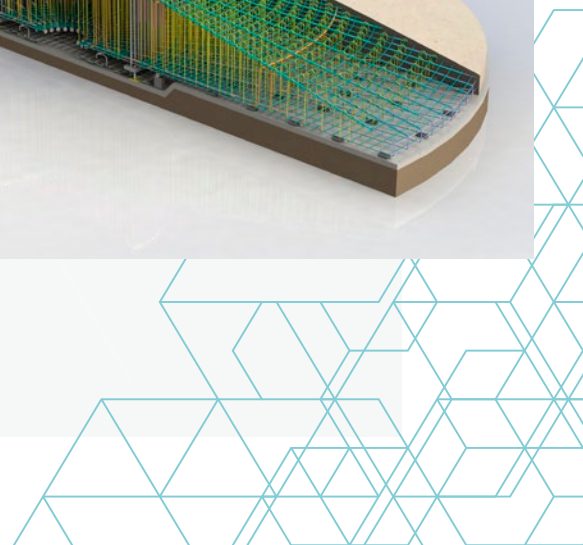
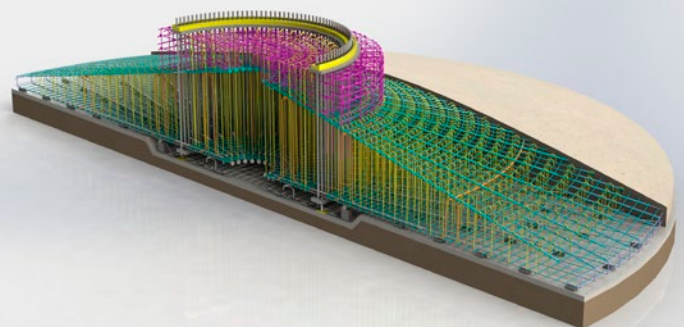
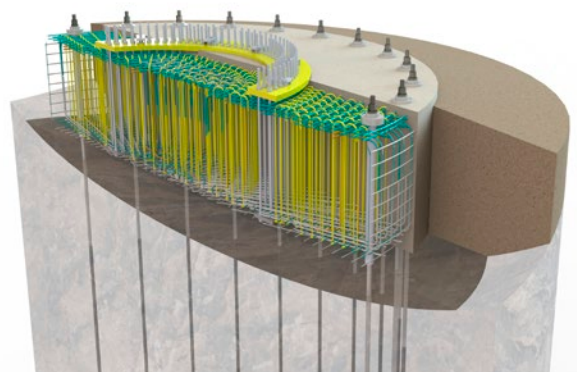

FAST MANUFACTURING OF FOUNDATION COMPONENTS

Our designs are seamlessly integrated with production. We can have the foundation components ready for shipping starting from three weeks. Certified in-house manufacturing in seven countries and our global warehousing network guarantee fast and flexible component deliveries.



EFFICIENCY IN INSTALLATION

Scheduled delivery of materials simplifies site planning and resource allocation. The delivery includes step-by-step instructions for assembly.

Peikko's foundation solutions offer the fastest installation in the field. Peikko's Foundation System or Rib Gravity Foundation can be completed in just four days. Installing Peikko's Rock Foundation will take two weeks spread over a longer period of time, due to the complex installation setup, but will provide remarkable cost savings.



Skanska - John Inge Mathiense

📍 OPTIMIZE AND BENEFIT WITH PEIKKO

By choosing Peikko as your foundation partner, you can optimize the foundations of your entire wind park and benefit from it. We can optimize the suitable foundation type to fit your soil conditions and cost drivers, choosing the most efficient solution for each foundation and building process.

With our solution, the design, manufacture of components, as well as timely deliveries on site are guaranteed. In addition, the savings made on steel and concrete add extra efficiency by optimizing installation time and the need for transportations.

Foundations made easy, efficiently, and with the lowest CO₂ emissions in the field!

www.peikko.com/wind

Video: Peikko's Rock Foundation in Roan Wind Park, Norway



A faster, safer, and more efficient way to design and build

Peikko is a leading global supplier of slim floor structures, wind energy applications and connection technology for precast and cast-in-situ. Peikko's innovative solutions offer a faster, safer, and more efficient way to design and build.